

Digital Force Gauges

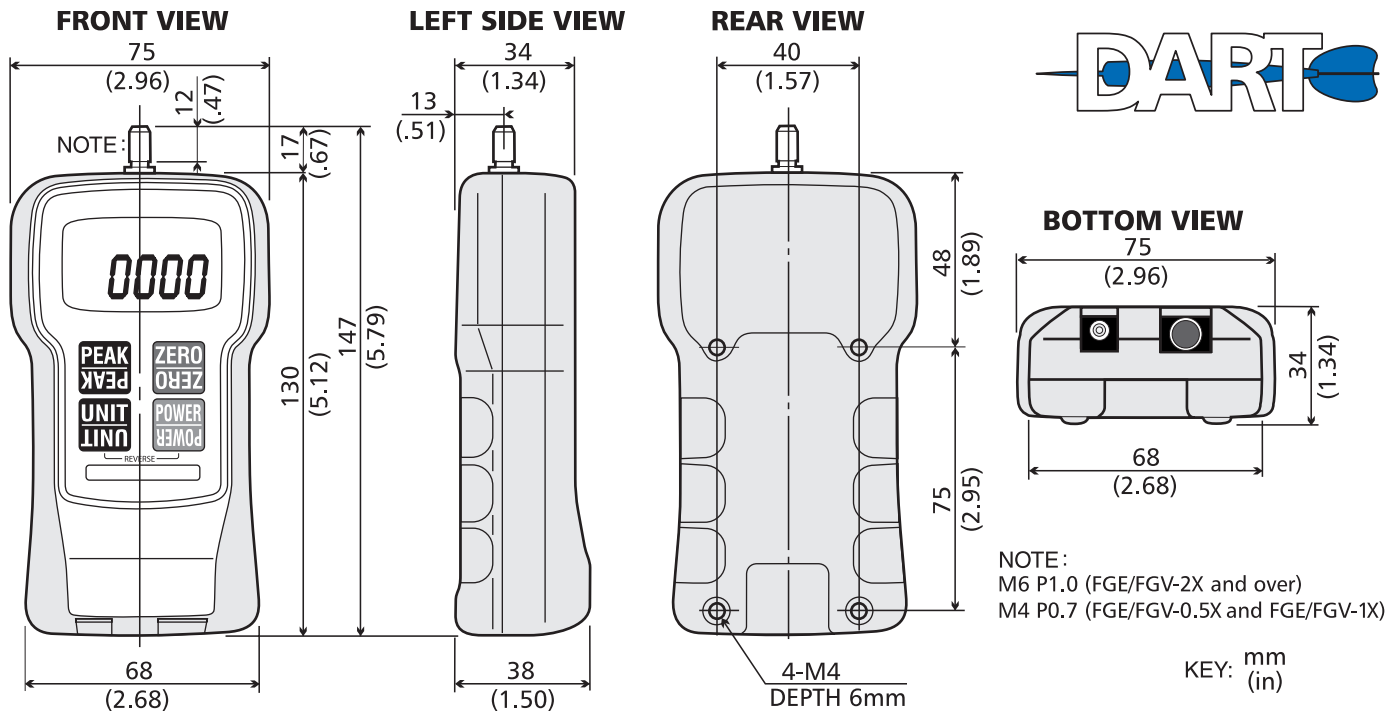

FGE - X and FGV - X DART SERIES SPECIFICATIONS

FGE-X Model	FGE-0.5X	FGE-1X	FGE-2X	FGE-5X	FGE-10X	FGE-20X	FGE-50X	FGE-100X
FGV-X Model	FGV-0.5X	FGV-1X	FGV-2X	FGV-5X	FGV-10X	FGV-20X	FGV-50X	FGV-100X
Capacity	0.5 lb (8 oz) 200.0 g 2.000 N	1 lb (16 oz) 500.0 g 5.000 N	2 lb (32 oz) 1,000 g 10.00 N	5 lb 2,000 Kg 20.00 N	10 lb 5,000 Kg 50.00 N	20 lb 10.00 Kg 100.0 N	50 lb 20.00 Kg 200.0 N	100 lb 50.00 Kg 500.0 N
Resolution	0.001 lb (0.01 oz) 0.1 g 0.001 N	0.001 lb (0.01 oz) 0.1 g 0.001 N	0.001 lb (0.01 oz) 1 g 0.01 N	0.001 lb 0.001 Kg 0.01 N	0.01 lb 0.001 Kg 0.01 N	0.01 lb 0.01 Kg 0.1 N	0.01 lb 0.01 Kg 0.1 N	0.1 lb 0.01 Kg 0.1 N
Accuracy	±0.2% F.S.							
Display	4-Digit LCD, 12mm high. Reversible by the push of a button. Minus sign for tension.							
Display Update	0.05, 0.1, 0.2, 0.3, 0.5, 1 sec							
Sampling Rate	1000 times per second							
Overload	200% of F.S.							
Power	Rechargeable Ni-Cad battery or AC adapter/charger							
Output (FGV-X model only)	Analog: ±1 VDC (through a 12 bit D/A converter) RS232C: Baud rate (19200, 9600, 4800, 2400 bps selectable), commands control							
Auto Power Shut-Off	Yes (not active if adapter/charge is in use)							
Battery Charge	12 hours (when fully charged)							
Recharge Time	Approximately 18 hours when fully discharged							
Temperature Range	32° - 104°F (0° - 40°C)							
Dimensions	5.1" L x 2.9" W x 1.5" H (130 mm x 75 mm x 38 mm)							
Weight	1 lb (450 g)							
Standard Accessories	AC adapter/charger, carrying case, hook, chisel, flat head, notched head, hanger, cone head, extension rod, inch adapter. FGV-RS232CABLE is included with FGV-X series only)							
Approvals	CE approved							
OPTIONAL	NIST certs with data							

FGV - X OUTPUT SPECIFICATIONS

RS232C Output Port	Selectable baud rate: 2400, 4800, 9600, 19,200bps	Data length: 8 bits	Stop bit: 1 bit	Parity: none	Software flow control: none
Analog Output Port	±1 VDC output (through a 12 bit D/A converter)				
Overload Output	One NPN OC transistor for tension, one NPN OC transistor for compression				