



TENSITRON, INC.
733 S. Bowen Street
Longmont, CO 80501
USA

Phone: (303) 702-1980
Fax: (303) 702-1982

E-mail: tensionmeters@tensitron.com
Web Site: www.tensitron.com

**Operating Instructions
ACX-Series
Digital
Aircraft Cable Tension Meter**

PERFORMING A 5-POINT, MULTILINERIZATION CALIBRATION

(If you only need to verify that the calibration you've selected is accurate, go to the "How To Check Accuracy" section on the preceding page.)

<u>INDEX</u>	<u>PAGE NO.</u>
Accuracy, How to Check.....	12
Analog Output (Option).....	4,8
Audio.....	3
Backlighting.....	3
Batteries, Charging.....	2
Calibrations, Custom.....	7,13
Calibration, Naming.....	4
Contrast.....	3
Data Logging.....	3,5
Display/Refresh Rates.....	3
Features.....	11
Flow Chart.....	6-7
Memory Function.....	2
Quick Start Instructions.....	2
Selecting Cable Size.....	2
Serial Communications (Option).....	4
Standard Instruments.....	9
Tension Units.....	2
Zeroing.....	2

Step 1: From the Main Display press **↑** or **↓** arrows until you reach **Setup**. Press **ENTER**. Press the **↓** arrow button until you reach **Cal Tension**. Press **ENTER**. The screen will display: **Setup, Calibrate Tension, Enter Password**. Press the **ENTER** button once, the **↑** arrow button once and the **ENTER** button once more. *(These three inputs are the password.)* Now the screen will display **Setup, Calibrate Tension** and you will be able to scroll down the list to select the description that you want to use for the new calibration. When this new description is highlighted, press **ENTER**.

Step 2: Next you will be prompted **ENTER WEIGHT 1**. Using the **↑** and **↓** arrows select a minimum tension value (*do not use zero*). Press **ENTER**. Select increasing weight values for **WEIGHT 2 THRU 4** (No. 4 being the maximum weight value). At each weight number select your weight value using the **↑** and **↓** arrows. **ENTER** each selection. *Next you will calibrate the instrument to the weight values you just selected. (To simulate tension loads for calibration, take a sample length of your material and suspend it from above. Next hang weights from your material in the weight values you previously selected in "enter weights 1 through 4".)*

Your instrument will now prompt you **PLACE WEIGHT 0**. With zero tension applied to the instrument press **ENTER**. Next you will be prompted **PLACE WEIGHT 1**. Suspend the exact weight value from your material that you previously selected. Engage instrument to the tensioned material and then press **ENTER**. Next suspend weight value 2 from your material, engage the instrument to your tensioned material and press **ENTER**. Repeat procedure for steps 3 and 4. Once you have entered the value for **WEIGHT 4** you have finished the calibration and will be returned to the Main Display. Your main display will now indicate the description of the calibration you've just entered. This indicates you have now selected the calibration you just performed. To change calibration use the **↑** or **↓** arrows until you reach **SELECT MATERIAL**. Follow procedures outlined in Section 3.5.

HOW TO CHECK ACCURACY

To verify the accuracy of your instrument, simulate a tension load on your cable by suspending known weights to a sample length of the cable. (See Figure 1) Then verify these values with the instrument, i.e.: if a 100 lbs weight is freely suspended from a single length of cable, the cable is now tensioned to 100 lbs, and your instrument should indicate 100 lbs on the display. To correctly obtain readings, first zero your instrument in the attitude it will be used for testing, then engage the instrument to the tensioned cable and note the reading. When performing this test make certain your cable diameter is dimensionally within tolerance (+/- .003" of size), and not out of round.

NEVER SIMULATE TENSION LOADS ON THESE INSTRUMENTS BY USING A CALIBRATION BAR! Doing so will damage the instrument to the point of failure.

KEEP IT SIMPLE. Only simulate tensions using free-hanging weights on correctly-sized cables. Never use any device that attempts to convert rotational torque values into tension loads, as these types of systems are highly inaccurate.

When calibrating instruments use lb weights values only. (For optimum accuracy use weights traceable to National Standards.)



Custom Calibrations for the ACX-Series of Digital Tension Meters

The **Calibration** feature is password protected. In order to perform a **Custom Calibration** a series of key inputs are required. **Warning:** This procedure will erase previous calibration data. Only a qualified testing laboratory with traceable weights and standards should perform a calibration.

Sec 1. SAFETY.

WARNING: When using cordless, electronic instruments, always follow basic safety precautions to reduce the risk of fire, electric shock and personal injury.

READ AND SAVE ALL INSTRUCTIONS FOR FUTURE USE. Before use, ensure all users read and understand this manual, as well as any labels packaged with or attached to the instrument.

1. **KNOW YOUR INSTRUMENT.** Read this manual carefully to learn your tension meter's applications and limitations, as well as the potential hazards associated with this type of instrument.
2. **AVOID DANGEROUS ENVIRONMENTS.** Do not use your instrument in the presence of explosive atmospheres (gaseous fumes, dust or flammable materials). Do not submerge your instrument in liquids.
3. **USE THE RIGHT TOOL OR INSTRUMENT.** Do not use this instrument to do a job for which it is not recommended.
4. **CHECK FOR DAMAGED PARTS.** Inspect instrument before use. Check for any binding of moving parts, improper mountings, broken parts and any other condition that may affect operation. Do not use a damaged instrument. Tag damaged instrument "DO NOT USE" until repaired. For repair, send instruments directly to Tensitron, Inc.
5. **GUARD AGAINST ELECTRIC SHOCK** when connecting power supply to voltage source.
6. **MAINTAIN INSTRUMENT CAREFULLY.** Keep handles dry, clean and free from oil and grease. Do not lubricate. All roller bearings are sealed.
7. **DO NOT USE INSTRUMENT IF** it has received a sharp blow, been dropped or damaged in any way. Do not disassemble. Incorrect reassembly may result in the risk of electric shock, fire or exposure to battery fluids. If instrument is damaged return it to Tensitron, Inc. for repair.
8. **STANDARD POWER SUPPLY IS RATED FOR 100-240 VAC** and includes several "blades" allowing use with European, US, Australian and other plug configurations.
9. **DO NOT USE INSTRUMENT WHEN TEMPERATURE** is below 35°F or above 115°F. Charging in direct sunlight or near a heat source will not produce a full charge and may permanently damage battery pack.
10. **STORE INSTRUMENT AND CHARGER** in a cool, dry place. Do not store where temperatures may exceed 120°F or fall below 35°F for storage times less than one month. Never let LCD display or battery pack assembly freeze.
11. **WARNING:** Only use battery pack assemblies provided by Tensitron, Inc. with your meter (P/N: ACX-260). Other types of batteries may leak or explode, causing personal or property damage if charged in this device.

Figure 1, Simulating Cable Tension

Sec. 2. CHARGING INSTRUMENT BATTERIES.

1. Connect power supply cable to instrument.
2. Plug the power supply into a 100 – 240 VAC outlet.
3. Full charge of battery assembly takes approximately eight hours.
4. Battery pack assembly cannot be overcharged, however instrument will remain on while plugged into power supply.
5. Fully charged battery assemblies will operate approximately six hours +/- 20% depending upon usage and backlighting intensity.
6. Battery charge level is indicated in the upper, right-hand corner of display.

Sec. 3. OPERATION: QUICK START.

1. **TURN UNIT ON** by pressing **ON** button. Display shows: **Tension** (Lbs, Newtons, or Kilograms), **Cable** size selected and battery charge level.
2. **MEMORY FUNCTION.** Depress the **MEMORY** button to store and display up to five separate tension readings, plus the average (**AVG**) of these stored values.
3. **MOVE BETWEEN SCREENS** by pressing either the **↑** or **↓** arrows. To make, or enter a selection, depress the **ENTER** key. To exit a setting, depress the **ESCAPE** key.
4. **ZERO THE INSTRUMENT** before taking readings by holding the instrument in the attitude in which it will be used, and with no load applied press the button marked **ZERO**.
5. **READING OF TENSION.** Variations in materials and sizes affect tension readings. It is essential to select the correct material and size from the calibration menu before use, or values may be incorrect.
6. **SELECT MATERIAL.** From the Main Display (first screen seen when unit is turned on) use the **↑** or **↓** keys until **SELECT MATERIAL** is displayed. Press **ENTER**. Next toggle through the various selections using the **↑** or **↓** arrows until correct cable size is highlighted, and press **ENTER** to make your selection. *If your specific material is not listed, follow the calibration instructions included at the end of these instructions, or send a sample and the instrument to Tensitron for a custom calibration.*
7. **SELECTING TENSION UNITS IN LBS, KILOGRAMS or NEWTONS.** Press the **↑** or **↓** keys until **TENSION UNITS** is displayed. Press **ENTER**. Next, select: **Lbs**, **Kilograms** or **NEWTONS** and **ENTER** selection.
8. **ENGAGE INSTRUMENT TO TENSIONED MATERIAL.** For best accuracy hold the instrument in the attitude the measurement will be taken in and press **ZERO**. Push “closure bar” away from the instrument handle to raise the outer cable guides. Engage the tensioned material by routing the cable so that it falls under the outer cable guides and over the center, contact point. Squeeze the “closure bar” shut until it locks into position beside the handle, and note the tension reading.

FEATURES

- * Large, easy to read, graphic display with adjustable backlighting and contrast.
- * Display shows Tension, Battery Charge Level, and Cable Size selected.
- * Push the MEMORY button to activate the Memory Function to store and display up to five separate tension readings plus the average value (AVG) of these stored readings.
- * Select tension value to indicate either in lb, Kilograms or Newtons.
- * Accuracy is +/- 2% full-scale for all menu-selectable calibrations. Accuracy for custom calibrations is material specific.
- * Up to 10 calibrations can be programmed into instrument. (All calibrations are password protected to provide due diligence against unauthorized changes).
- * Adjustable LCD refresh rates allow for stable, digital readings.
- * All models typically available from stock.
- * All models factory calibrated and ready for use.
- * Includes easy to use, cable diameter gage to accurately determine correct cable size.
- * All calibration values traceable to National Standards. Calibration



Cable Diameter Gage

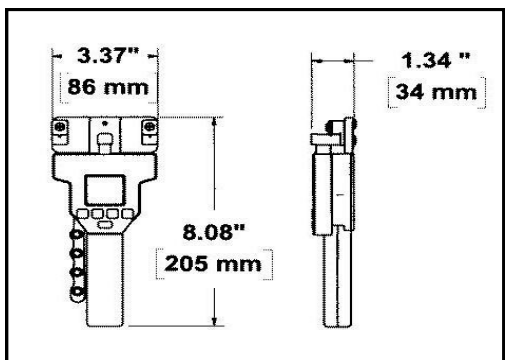

ACX-100, ACX-250, ACX-CWT, and ACX-CMB

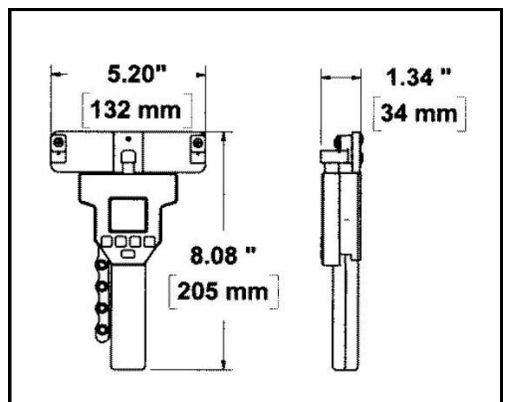

ACX-500

SPECIFICATIONS:

- Approximate weight is 1-1/2 lbs (Weight varies depending upon instrument configuration).
- Re-chargeable NIMH battery with power supply provided. Approximately 6 hours of operation per battery charge depending upon backlighting intensity.
- Power Supply operates with input voltages from 100 – 240V and includes several, interchangeable “blades” allowing use with European, US, Australian, and other plug configurations.
- Instruments may be operated continuously while connected to power supply.
- Durable, lightweight carrying case with protective foam inserts.

Sec. 4. ADDITIONAL TECHNICAL INFORMATION.

1. **DATA LOGGING.** (*Optional feature*). From the Main display use the **UP** or **DOWN** keys until **Data Logging** is displayed. Press **ENTER**. Next, select **Logging Rate** and select Hz rate which your data will be collected in (choices are from 1Hz to 100Hz). Next select **Duration** and select the time period the data will be collected over by using the **UP** or **DOWN** keys. Finally select **Begin Logging** when you are ready to collect your data. Note: You can stop collecting data at any time by simply depressing **ESC** (escape). Collected data will remain in memory, regardless if instrument is turned off, and will only be overwritten once new data is collected. To view collected data select **View Data Log** and press **ENTER**. Logged Data can also be uploaded to your computer via the RS-232, serial port. Refer to **Sec 4.12, Uploading logged data**, for specific instructions.

2. SPEEDING UP OR SLOWING DOWN DISPLAY LCD REFRESH RATES -

DAMPENING ADJUSTMENT. To either speed up or slow down the rate at which tension values refresh on the display. Use the **↑** or **↓** keys, select **SETUP**, and press **ENTER**. Next select **Dampening** and after entering this selection, choose the refresh rate from: **1Hz, 2Hz or 5Hz**. When new rate is highlighted, press **ENTER**.

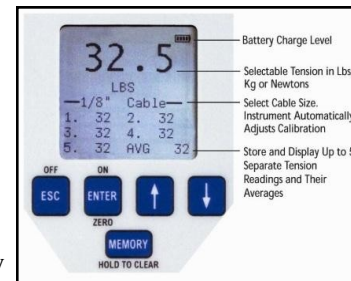

3. **AUDIO.** Turn on or off audio beep (with key inputs) by selecting: **SETUP**, then select **Audio**, and finally either select **ON** or **OFF**.

4. **BACKLIGHTING INTENSITY.** Increase or decrease backlighting intensity by selecting: **SETUP**, then **BACKLIGHT**, and finally intensity level.

5. **DISPLAY CONTRAST.** Increase or decrease LCD display contrast by selecting: **SETUP**, then select **CONTRAST**, and finally manipulate contrast using the **↑** or **↓** keys. Remember to **ENTER** your new setting.

6. **VERSION.** Instrument Model No. along with software version information can be viewed under **SETUP** and then selecting **Version**.

7. **CUSTOM CALIBRATIONS.** Calibrations are password-protected to prevent unintended changes. See Page 13 for step-by-step instructions, or contact your Metrology Department or Tensitron, Inc. for assistance. If you only want to verify your instrument's accuracy refer to: **How To Check Accuracy, on Page 12.**

Section 4 (Con't.)

8. **CUSTOM CALIBRATION NAMES.** Custom Calibrations (listed as Custom 0 - 9) can be renamed so that the Main Display indicates your name for the calibration instead of Custom 1, 2, etc. From the Main Display use the **↑** and **↓** keys until **SETUP** is selected. Press **ENTER**. Using the **↑** and **↓** keys select **Custom Names**. Press **ENTER**. Next, using the **↑** and **↓** arrows select calibration number, or previous name you wish to rename. Press **ENTER**. Using the **↑** and **↓** keys select the number, letter or character for the beginning of your new name. Press **ENTER**. Follow the same procedure for each sequential letter or space of your new description. Continue pressing **ENTER** until all spaces in the description have entered values. Once your new name has been entered you will be returned to the **SETUP** screen. To select your new calibration follow the procedures outlined in Sec.3.6.

9. **MONITORING TENSION THROUGH THE ANALOG OUTPUT** (*Optional feature*). Output values are: 0 – 5 VDC or 4 – 20 mA. Connect Analog Output Cable to receptacle located on the bottom side of instrument. Connect output cable leads to the analog input of your measurement or control device. The **RED** lead is Voltage +, the **WHITE** lead is mA, and the **BLACK** lead is ground. From the main display use the **↑** and **↓** keys until you reach **SETUP**. Press **ENTER**. Next using the **↑** and **↓** arrows select **ANALOG OUTPUT**. Press **ENTER**. Using the **↑** and **↓** arrows select from: **ANALOG TENSION CURRENT OR ANALOG TENSION VOLTAGE**. Once correct selection is made press **ENTER**.

10. **CALIBRATION OF ANALOG OUTPUT.** (*Optional feature*) From Main Display press the **↑** and **↓** keys until you reach **SETUP**. Press **ENTER**. Press the **↑** and **↓** keys until you reach **CALIBRATE ANALOG**. Press **ENTER**. Using the **↑** and **↓** keys adjust display to show the value at which the instrument reads maximum current or voltage. Press **ENTER**.

11. **SERIAL DATA COLLECTION (RS-232 option).** (*Optional feature*) Instruments outfitted with the optional RS-232 feature (designated with a -E in the part number) support serial communications as follows:

- The baud rate is 9600 with no parity bit, 8 data bits and 1 stop bit (9600 8N1).
- Serial communications will work with most PCs with a cable up to 15 feet long.
- Setting the dampening rate on the instrument to “1 Hz + Serial”, “2 Hz + Serial” or “5 Hz + Serial” will cause the instrument to output the tension values at a rate of once, twice or five times per second, respectively. The dampening rate can be set by going to the **SETUP** menu, selecting **DAMPENING**, adjusting the value of the dampening rate with the **↔** and **↔** buttons and then pressing the **ENTER** button.
- The units output serially will be the same units that are selected in the “Tension Units” menu. The currently selected tension units (such as Lbs,

STANDARD INSTRUMENTS

RANGE	RESOLUTION	STANDARD CABLE SELECTIONS
5-100 LBS	0.5 LB	1/16", 3/32", 1/8", 5/32"
20-250 LBS	0.5 LB	1/16", 3/32", 1/8", 5/32", 3/16"
40-500 LBS	1.0 LB	3/32", 1/8", 5/32", 3/16"
20-250 LBS	0.5 LB	CWT-5, CWT-10, CWT-15, CWT-20, CWT-25
20-250 LBS	0.5 LB	1/16", 3/32", 1/8", 5/32", 3/16", CWT-5 to CWT-25

Calibrations for 7/32" and for metric sized cables can be added to the cable selection menu upon request, however cables with diameters larger than 5/32" will only indicate up to approximately 90% of maximum tension range. For example, an instrument scaled for a maximum tension range of 250 lbs will display readings up to approximately 225 lbs on 7/32" or 3/16" diameter cables.



ACX-500

AVAILABLE OPTIONS FOR ALL INSTRUMENTS:

Note: Add option designator to the end of the part number. (For example, a Model ACX-250-E denotes a standard, ACX-250 with the optional RS-232, serial output function installed).



- **A** Analog Output option. 0-5 VDC or 4-20 mA with Software-definable ending sequences. Provided with 10' cable. Data outputted at 40 Hz.
- **E** RS-233 Serial Output option. Provided with 10' cable to Interface with your receiving device. Select data sampling rate from 1, 2 or 5 Hz.
- **D** Data Logging Option. Capture and play back data within a user-defined time window. Select the time window; then select the sampling rate (adjustable from 1-100 Hz). After capturing the data, review the data on the instrument's display or upload it using the 10' serial interface cable.

Instruments can be configured with any or all of these options.

Input Real-Time Serial Data into any Windows® application using any number of software wedge programs, such as WinWedge Pro® for Windows, or configure your Window's® operating system to capture the data via Hyper Terminal®.

e. Perform the following steps in order to log serial data from the instrument using Hyper Terminal on a PC and put it into a Microsoft Excel spreadsheet:

- 1) Ensure that the dampening rate is set to "1 Hz + Serial", "2 Hz + Serial" or "5 Hz + Serial".
 - 2) Connect the serial cable from the instrument to a serial port on your PC.
 - 3) Go to the Windows® Start Menu and choose Programs->Accessories->Communications->Hyper Terminal®
 - 4) In the Connection Description dialog box that pops up, type in a name for the new connection (you can use any name you wish to describe this file) and press the OK button.
 - 5) In the Connect To dialog box that pops up next, go to the drop down menu labeled "Connect Using:" and select the serial port you connected the cable to in step 2. It is most likely that you are connected to COM1.
 - 6) In the COMx Properties dialog box that pops up next, set the "Bits per second:" to 9600, the "Data bits:" to 8, the "Parity:" to None, the "Stop bits:" to 1 and the "Flow Control:" to None.
 - 7) Click the Apply button and then click the OK button.
 - 8) You should now see tension values appearing in the Hyper Terminal window.
 - 9) When you are finished collecting data, close Hyper Terminal.
 - 10) To save the data in Microsoft Excel® format, use Microsoft Excel® to open the file you saved the data log in and save it as an Excel® file.
- 12) **UPLOADING LOGGED DATA** (*Optional Feature*) **via RS-232, SERIAL COMMUNICATIONS.**
- a. Refer to the previous section, Sec. 3.10, Serial Data Collection (RS_232 option) and configure communication protocols as outlined. Note: Step c has no effect on transferring stored data and can be adjusted to any setting.
 - b. To retrieve, or upload logged data from the instrument, send a lower case 'd'.
 - c. Collected data will remain in memory, regardless if instrument is turned off, until overwritten with new data.

FLOW CHART

Model: ACX-SERIES DIGITAL TENSION METER

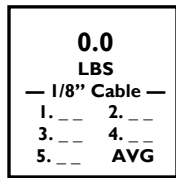

Use ↑ and ↓ keys to navigate main screens

Use ENTER to reach subscreens and ↑ and ↓ keys to make selections.

